

**450-3324 Swage Mount Socket,
 For .059 (1,52) to .062 (1,57) Diameter Pins**

Recommended mounting hole .144 (3,66) + .002 (0,05) - .001 (0,03), #27 drill

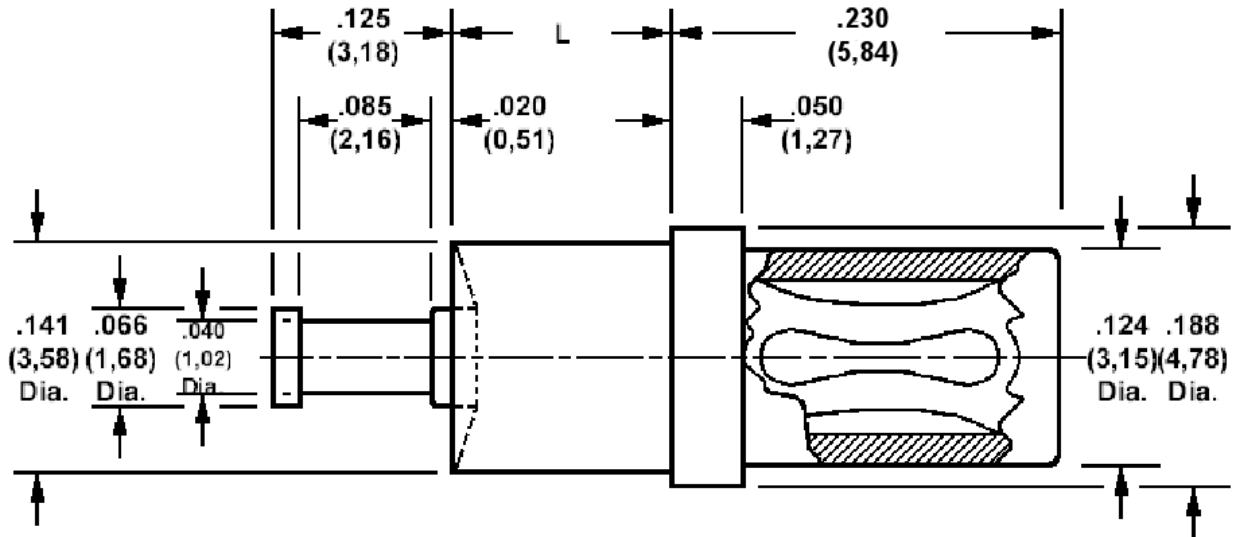

Min hole depth .204 (5,18)

**How to order code
 450-3324-YY-XX-00**

Basic Part No YY = Board thickness XX = Finish

DIMENSIONS		
Dash No (YY)	'L'	Board Thickness
-01	.058 (1,47)	.031 (0,79)
-02	.089 (2,26)	.062 (1,57)
-03	.120 (3,05)	.094 (2,39)
-04	.151 (3,84)	.125 (3,18)

MATERIALS				
Component	Material	Finish (-03)	Finish (-04)	Finish (-06)
Body	Brass	Gold over Nickel	Electro Tin	Electro Tin
Spring	Beryllium copper	Gold over Nickel	Electro Tin	Gold over Nickel

TOOLING	
Recommended Swaging Tools:-	
Anvil	435-6427-01-00-00
Roll Punch	435-6656-01-00-00