

## 435-3803, Manual Bench Press

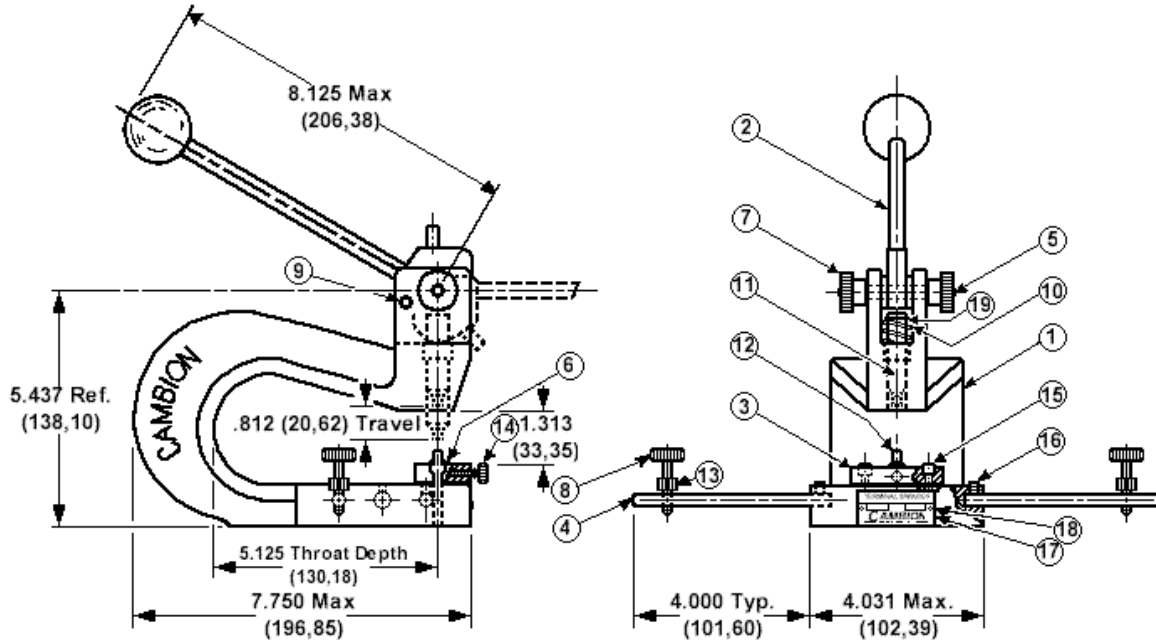

How to order code  
 435-3803-01-00-00

### BENCH PRESS SPARES

Fig.	Description	Part Number
1	Base, Cast Iron	430-3806-01-00-10
2	Handle Assembly	430-3807-01-00-00
3	Anvil Plate	430-3812-01-07-00
4	Board Support Rod	430-3813-01-07-00
5	Cam Shaft	430-3814-01-00-00
6	Brass Locking Pad	430-3815-03-00-00
7	Domed Hex Nut (was thumb nut) (5/16 - 18)	931-3684-01-29-00
8	Thumb Screw (10 - 24)	330-3817-01-12-00
9	Spring Pin	315-3811-01-00-00
10	Compression Spring	345-3818-01-00-00
11	Punch	See product pages for part number
12	Anvil	See product pages for part number
13	Thumb Nut (10 - 24)	310-3829-01-12-00
14	Set Screw	330-1914-01-12-00
15	Machined Socket Head Screw (8 - 32)	330-0176-07-12-00
16	Set Screw (8 - 32)	330-1914-01-12-00
17	Name Plate	610-5579-01-00-00
18	Drive Screw (No. 4)	330-3820-01-00-00
19	Retaining Ring	345-3821-01-00-00
20	Tool Kit	390-0081-01-00-00

**Tool installation instructions****Stage****Instruction**

1. Loosen screws (15) in anvil plate (3)
2. Install anvil (12) in anvil plate (3)
3. Remove domed hex nuts (were thumb nuts) (7), cam shaft (5) and handle assembly (2)
4. Install retaining ring (19) on punch (11)
5. Install punch, inserting through compression spring (10)
6. Reassemble handle assembly (2), cam shaft (5) and domed hex nut (were thumb nuts) (7)
7. Bring handle forward so that punch (11) touches anvil (12)
8. Line up punch and anvil by moving anvil plate (3)
9. Lock anvil plate in place by tightening screws (15)
10. Adjust anvil height by screwing into anvil plate, so that the clearance between punch and anvil, with handle all the way forward, is slightly less than the thickness of the board to be swaged
11. Lock anvil in place by tightening set screw (14)
12. Properly locate board support rods (4), (if needed) to fit board to be swaged
13. Adjust thumb screws (8) so that the board will be level, and lock in place with thumb nuts (13)