

410-4522 Component Clip, .040 (1,02) Slot, Press mnt, Insulated, Capped Plunger

Recommended mounting hole .203 (5,16)

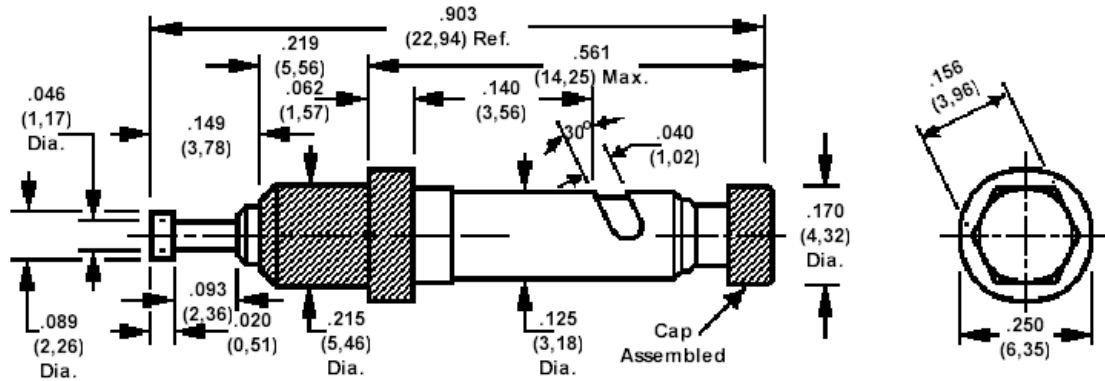

Recommended Lead Wire Sizes - #30 AWG (.010) (0,25) Min. Thru #22 AWG (.025) (0,64) Max.

How to order code
410-4522-01-05-19
Basic Part No

Basic Part Number	For Panel Thickness	Flashover at Sea Level (VRMS)	Capacitance (pF)
410-4522-01	.040 (1,02) to .125 (3,18)	2500	0.9

Component	Material	Finish
Insulator	Teflon	White
Cap	Nylon	Natural
Housing	Brass	Electro Solder
Plunger	Brass	Electro Solder
Spring	Cres. Steel	Passivated

Teflon is a registered trademark of Dupont